

Shrinking a Power Supply and the Challenge to Maintain High Reliability

Created by

Advanced Energy Industries, Inc.

Shane Callanan, director of Innovation Engineering at Advanced Energy

Industries, Inc. considers the challenges associated with reducing the overall size of a power supply while at the same time maintaining the high reliability of the solution you come up with.

Abstract

In the last few years, as the technology of power supplies has changed we have seen tremendous improvements in the power density of solutions being offered by many leading companies. This is in direct response to customer demands of smaller solutions, lower cost, and increased reliability. However, as you reduce the size of your power supply you need to ensure that component temperatures are kept low or run the risk of reduced reliability. This paper will look at the challenges facing a power supply designer and how we can achieve this.

Table of Contents

Introduction	2
Identifying if Your Power Supply Needs a Cooling System	2
Basic Principals of Thermal Transfer and How These Relate to Thermal Operating Limits	3
Heat Sinks vs. Fans	3
Testing Your Design	5
Derating	6
Summary	7
About the Author	7

Introduction

If a power supply could convert all of the power entering into it into useable power output, it would be 100% efficient. However, a certain amount of energy is ‘lost’ during each conversation stage as you convert from one voltage level to another. In the process of these conversion stages a power supply will consume some energy. Typically this is expressed as a percentage.

$$\eta = P_{in} / P_{out} \text{ Eqn (1)}$$

Where P_{in} = Input power
 P_{out} = Output power
 η = Efficiency (%)

You will recall from first principals that energy cannot be created or destroyed, but instead can only be changed from one form to another. Any inefficiency in a power supply will be converted to heat, as this is the only medium for a supply to convert the energy. This will cause a temperature rise internally on components and will cause a reduction in reliability of the power supply. In light of this, it is imperative that power supply designers have the required skill-set to deal with this heat. In electronic equipment, the most prominent stresses are temperature, voltage, vibration, and temperature rise. The effect of each of these stresses on each of the components must be considered. In order to achieve good reliability, various derating factors have to be applied to these stress levels. The derating has to be traded off against cost and size implications. It will require careful consideration if the final design needs additional cooling.

Great care and attention to detail is necessary in order to reduce thermal stresses. The layout has to be such that heat-generating components are kept away from other components and are adequately cooled. Thermal barriers are used where necessary and adequate ventilation needs to be provided. The importance of these provisions cannot be overstressed since the failure rate of some components will double for a 10°C increase in temperature.

Identifying if Your Power Supply Needs a Cooling System

Upon reading a power supply datasheet, you will observe that the vendor will provide details on the operating temperature range. This will be in the form of either ambient temperature or case temperature, and sometimes it will be both. The aim of these is to set an operating boundary that will ensure the part will be used in a safe thermal environment. In particular, it ensures that the components on the power supply will not exceed thermal ratings that would either reduce their reliability or worse cause a breakdown of those components. The designer will have determined this boundary as they go through the design evaluation process and will often incorporate additional thermal heat dissipation in order to meet these requirements.

Basic Principals of Thermal Transfer and How These Relate to Thermal Operating Limits

There can be up to three methods by which heat is transferred from one location to another. These can be defined as follows:

- **Conduction:** This is the transfer of heat from one material to another. It is the heat transfer of kinetic energy from one molecule to another. Heat is transferred through a solid medium where a temperature difference exists between the two bodies. This mode of transfer can be easily modelled if compared to the flow of current within a conducting material. Different materials will either have a good or poor thermal conductivity. Materials that conduct heat will also in general conduct electricity well. In most cases internal components are bonded to a larger mass (e.g. heatsink), permitting a thermal path of low resistance. The heat will pass into the heatsink, and then the heatsink can be cooled by convection methods.
- **Convection:** This is where heat is transferred from a heat generating material to a moving surrounding fluid. In power supplies this surrounding medium is generally air, but in some cases we are starting to see fluid being introduced. Convection is governed by Newton's law of cooling, where we learn that the rate of convection heat transfer is proportional to the difference in temperature between the case temperature of the component and the fluid.
- **Radiation:** Radiation is the one way of getting heat away that does not require a medium for this to occur. Thermal radiation is the electromagnetic radiation emitted by a body due to its temperature. A good everyday example of this would be the sun radiating heat onto the earth's atmosphere. Unlike the other methods mentioned above this is not a linear event. Radiated heat is not easily modelled, as the surrounding environment will have a significant impact on the ability of a power supply to radiate heat away. It is not recommended for the designer to depend on this, as it is often difficult to accurately quantify.

Heat Sinks vs. Fans

From Eqn (1) above we can determine the power to be dissipated (P_{diss}), since this is a function of efficiency

$$P_{diss} = P_{out} \left(\frac{1 - \eta}{\eta} \right) \text{ Eqn (2)}$$

Where P_{diss} = Power to be dissipated

η = Efficiency

η = Efficiency (%)

Once you understand this, it will allow you start to consider if you need additional cooling in your design. If the answer is affirmative, you now have a number of options available. When designing a heat sink, remember that heat will travel in the direction of least thermal resistance. In light of this, perhaps less than 10% of the overall heat will be lost from the rear surface and sides of a power supply if a heat sink is properly designed into your heat management system. One important aspect to note that when considering the thermal resistance of a body, is that it will rise in line with temperature due to an increase in thermal radiation at these higher temperatures.

SHRINKING A POWER SUPPLY AND THE CHALLENGE TO MAINTAIN HIGH RELIABILITY

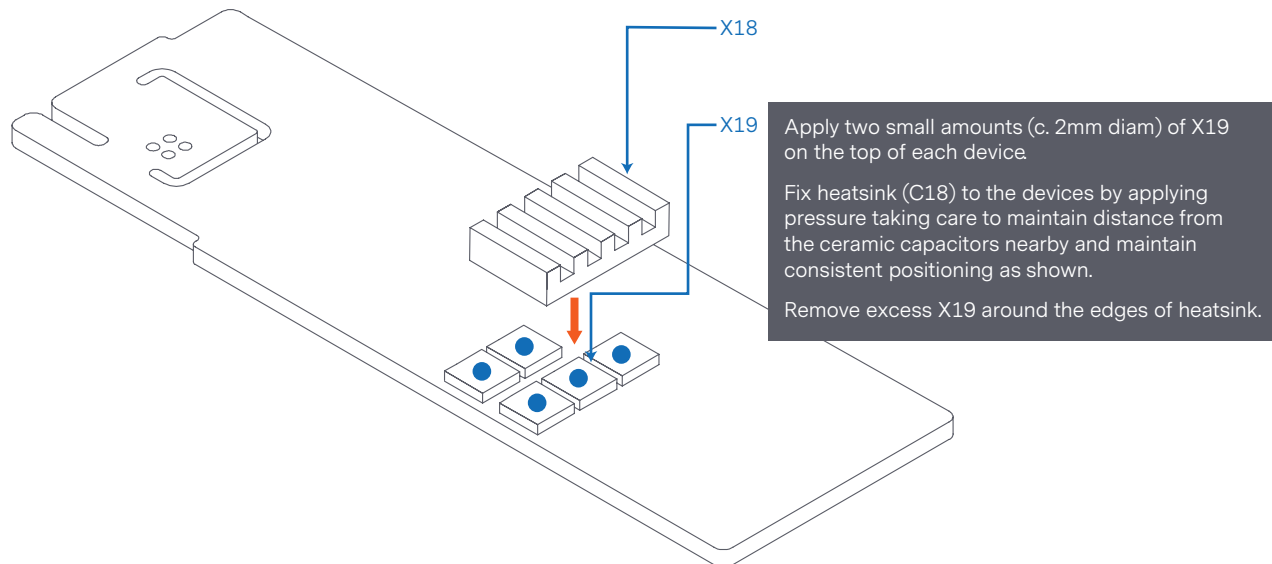

Figure 1: Heatsinks used to keep key components running at a lower temperature

Heatsinks can also be used to share heat amongst several key parts. This will ensure they share the same thermal profile which impacts on their electrical performance. In Figure 1 above we see the forward and freewheel FETs of a synchronous buck converter stage are attached to one heatsink. This not only increases their useable power, but also has an added functionality of keeping paralleled FETs at the same case temperature.

If it has been determined by calculation or experiment that passive modes of thermal cooling are not enough, then you will need additional cooling in the form of a heat sink or forced air-cooling. Forced convection is a very powerful method of cooling, and you have two options of implementing this. You can either use a fan in your design or specify a level of forced air-cooling for the customer. Remember, forced air-cooling functions by the volume of air that it can force across a component. You will also note that the volume of airflow will be fixed for any given fan, and velocity will vary with the cross section of the fan.

The optimum solution would be a combination of the two methods above. Heatsinks can be incorporated to take heat away from heat generating components, and with careful design, you can use fans to effectively remove the heat from these heatsinks.

SHRINKING A POWER SUPPLY AND THE CHALLENGE TO MAINTAIN HIGH RELIABILITY

Lead Forming Q4 and Q5

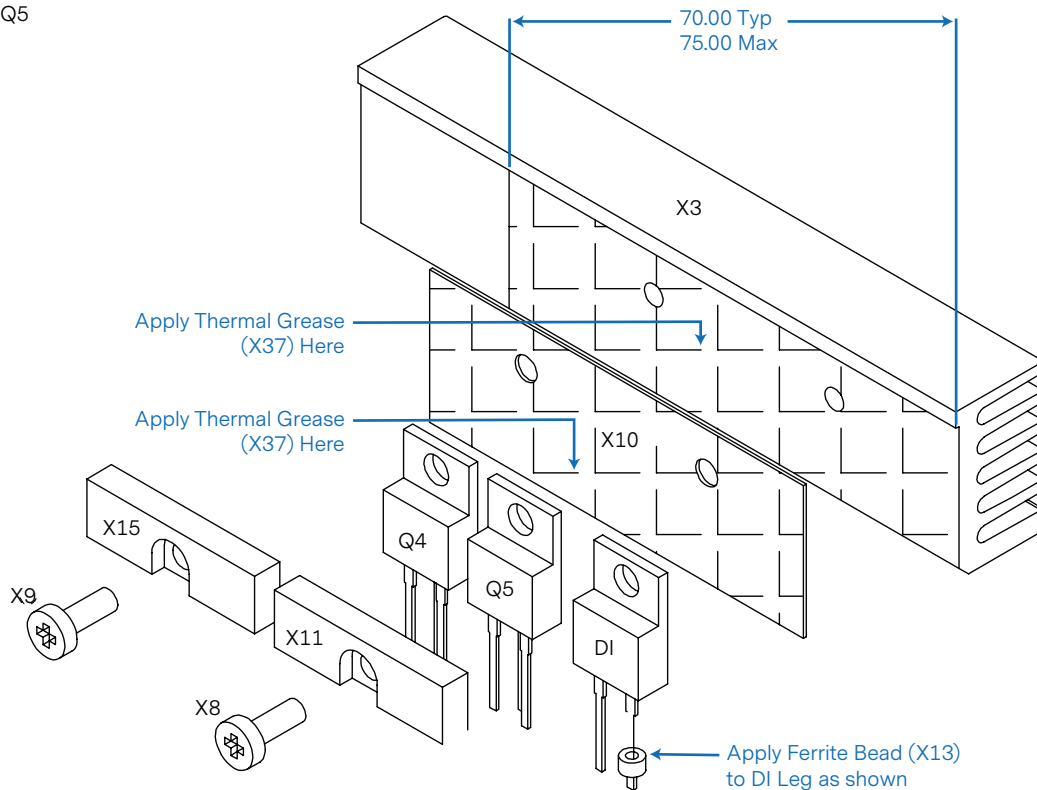
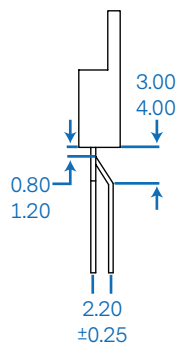

Figure 2: A combination of conduction and convection cooling provide effective thermal management

Figure 2 shows the heat-generating components of the Xgen PFC stage being fixed to a heat sink. The Xgen also incorporates a fan, which moves a volume of air directly across the heatsink to keep it thermally cool, which can provide up to 1340 Watts in a 1U height design.

Testing Your Design

Even though thermal profiling software continues to improve, it can be difficult to accurately model the flow of heat away from your key components. This is due to the complexity of heat transfer, because the airflow can be turbulent. This leaves the designer with the realization that the only way to 100% verify your approximations is to conduct testing in a thermally controlled chamber. In completing this, it is important to pay close attention to creating the correct convection conditions in your chamber. If the airflow is restricted then you may not get an accurate recreation of a real life application. Even though many thermal chambers have an internal fan to circulate air, you might find yourself gravitating towards using a wind tunnel with variable wind speed and thermal control.

Derating

As power supplies reduce in size, it is imperative that you either reduce losses or implement techniques to deal with the heat transfer effectively. If not, then you will be faced with two choices, either reduce reliability or derate. You do this by limiting the power dissipation of the components of the device itself. This lowering of the power limit is known as “derating” and is usually specified in datasheets using a “derating curve” (see Figure 3 below).

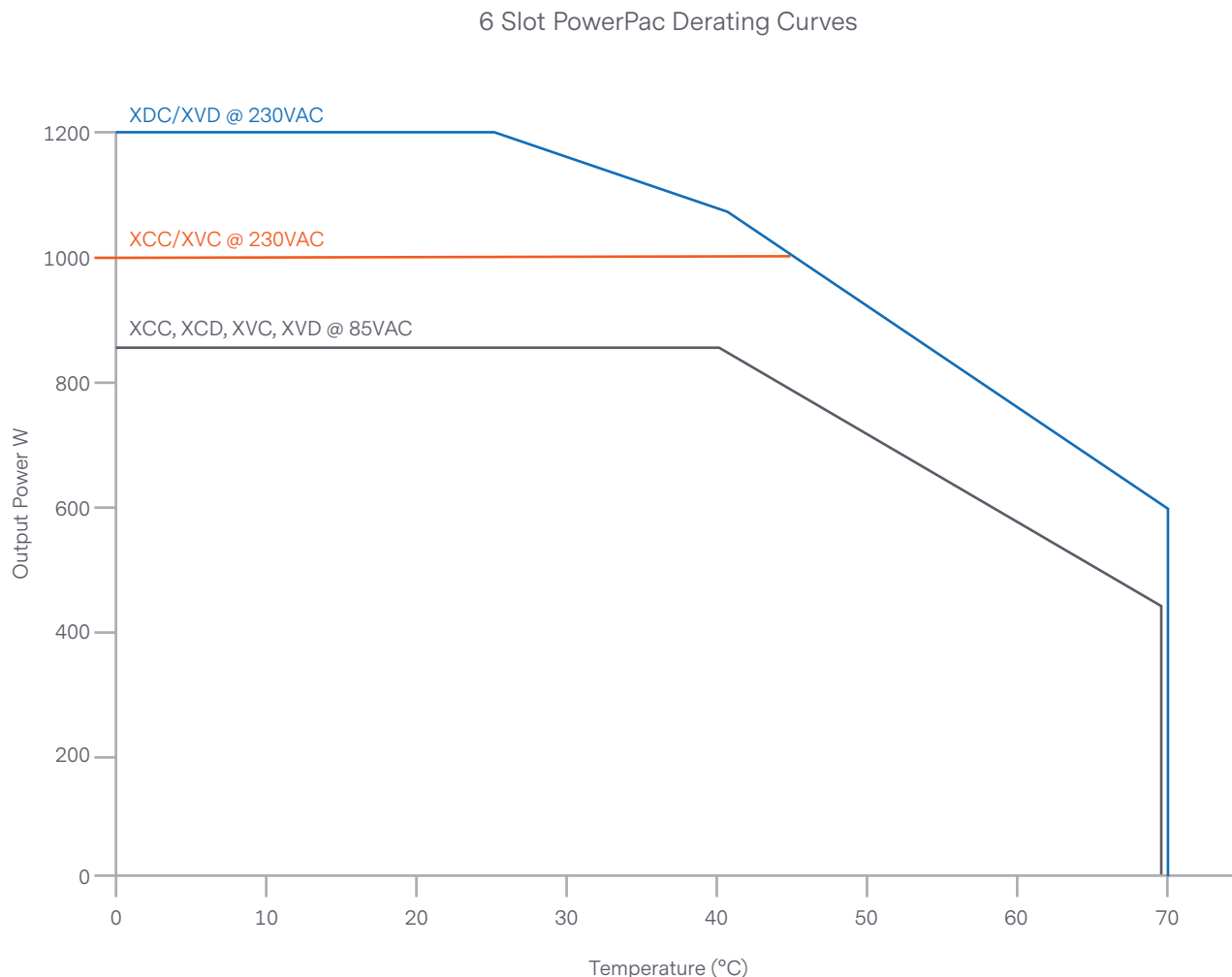

Figure 3: Thermal derating of the Xgen series

Figure 3 above shows the derating curves for the Xgen 6 Slot power supply. Taking the XCC/XVC model operating at 230 Vac as an example, the power supply is rated to output 1000 W from 0°C to 45°C ambient. Then from 45°C to 70°C, the power supply is then derated linearly to 600 W. The power supply is not rated for operation at ambient temperatures higher than 70°C. If the power supply is operated within these limits, any harmful thermal conditions are avoided.

Summary

As you reduce the size of your power supply, the key to maintaining reliability is a combination of reducing losses and effectively dealing with heat flow away from key components. As size decreases, losses need to be reduced accordingly. This approach, combined with better thermal management, will allow you to maintain reliability and lifetime of the final solution. The most important factor is good, careful design based on sound experience, resulting in known safety margins. This does not necessarily show up in any predictions and can lead to field failures.

About the Author

Shane holds a bachelor of engineering (honors) from Cork Institute of Technology. He was also awarded the title of chartered engineer by the Institute of Engineers of Ireland in 2002, and was elected to be Fellow in 2012. He currently holds the role of director of Innovation Engineering at Advanced Energy Industries, Inc.

Prior to joining Advanced Energy Industries, Inc., Shane joined the Excelsys Technologies team in early 2006, and he held the role of director of Applications Engineering. Prior to joining Excelsys, Technologies he held a number of senior engineering positions at Artesyn Technologies and also at EMC. He has considerable power supply design engineering experience and engineering team leadership experience in product development, NPI and customer program management.